



Description

It measures one component of the electric field vector based on the electro-optic technology. This Ultra-Wide Band sensor allows accurate measurements in almost any location and environment (air, liquids, gases) under harsh conditions.

Each eoProbe is delivered with a calibration certificate valid for 2 years.

This probe must be used with the eoSense instrument.

6 patents covers the eoProbe: EP2035845, EP2035846, US7769250, US8264684, CA2655034, CA2655447.

Main usage precautions

The probe and its fibre optic must not be submitted to mechanical constraints or shocks. The eoProbe must be handle with care and stored inside its provided suitcase.

Applications

E-field measurement in/for:

- Biological environment
- Specific Absorption Rate assessment
- Medium and high voltage systems
- Cold plasmas
- MRI
- Power electronics systems
- Railways
- Any liquid
- Antennas
- And many more

Main features

- Vector near and far E-field measurement
- Non-perturbative (no metal part)
- Withstand more than 10MV/m
- Ultra-WideBand
- Very compact design
- Remote measure up to 100 meters
- Fully insulated sensor

eoProbe versions

Reference	Environment	Sensitivity - Bandwidth	Type
P1tR05-BS5-air	Low permittivity (Air / oils)	250mV/m - 30Hz ... 10GHz	Transverse
P1tR05-BS1-air	Low permittivity (Air / oils)	500mV/m - 30Hz ... 50GHz	Transverse
P1IR05-BS5-air	Low permittivity (Air / oils)	50mV/m - 30Hz ... 10GHz	Longitudinal
P1IR05-BS1-air	Low permittivity (Air / oils)	200mV/m - 30Hz ... 50GHz	Longitudinal
P1tR05-BS5-bio	High permittivity (water based liquids)	50mV/m - 30kHz ... 10GHz	Transverse
P1tR05-BS1-bio	High permittivity (water based liquids)	200mV/m - 30kHz ... 50GHz	Transverse
P1IR05-BS5-bio	High permittivity (water based liquids)	50mV/m - 30kHz ... 10GHz	Longitudinal
P1IR05-BS1-bio	High permittivity (water based liquids)	200mV/m - 30kHz ... 50GHz	Longitudinal

All probes have 5 meters of fibre optic and a robust connector. At the quote, the fibre optic length may be proposed up to 15 meters. Longer distances are available with the fibre optic extension.

Type concept

Transverse type: the eoProbe measures the concerned E-field vector when it is orthogonal to the eoProbe

Longitudinal type: the eoProbe measures the concerned E-field vector when it is in line with the eoProbe

Main specifications *

Sensitivity and bandwidth	See above eoProbe versions table
Dynamic of measurement	$\geq 130 \text{ dB}\cdot\sqrt{\text{Hz}}$
Selectivity	$\geq 50\text{dB}$
Spatial resolution	$\leq 1 \text{ mm}$
Operating temperature	0 ... +50°C (32 ... 122 °F)
Operating pressure	0 ... 2030 hPa (0 ... 29.4 PSI)
Max E-field without damage	10 MV/m
Max B-field without damage	4.7 Tesla
Ingress protection rating	IP 67 (sensor only)
Chemical compatibility of gases	Air, nitrogen, plasmas, SF6
Chemical compatibility of liquids	Water, oils, alcohols, biological liquids
Probe cleaning	Clean lightly moistened with isotropilic alcohol
Fibre optic diameter	2.8 mm
Fibre optic minimum bend radius	40 mm

*Values are valid under certain conditions

eoProbe dimensions

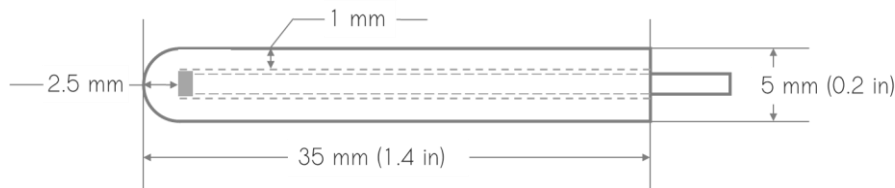

Permittivity ϵ_r

Crystal: 42

Air probe packaging: 3.3

Bio probe packaging: 23

Fibre optic: 5

Accessories

Ring to maintain 2 or 3 probes in the same direction

This ring maintains together in a very easy way, up to 3 probes to measure the 3 axis (X, Y and Z) of the electric field.

Marks are available on the ring to clearly identify the orthogonal components of the vector for the transverse probes.

2 transverse probes and 1 longitudinal probe can be used with this ring.

The ring material does not perturbate the measurement.

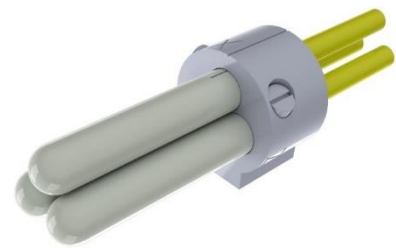

Reference: EOP-SH

Dimensions of the ring:

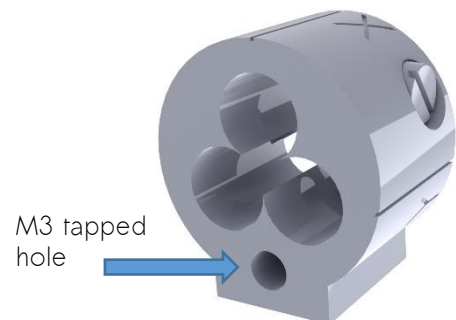
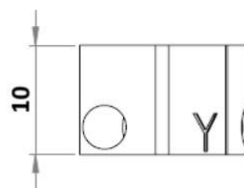
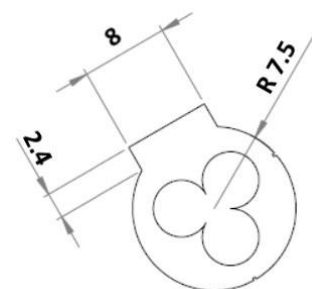

The flat area of the ring is used to fix it on Kapteos accessory called eoPod or on another fixing system via a M3 plastic screw (not provided).
It is not necessary to screw too tight the probes on this holder. A light torque is plenty enough.

Support to maintain 2 or 3 probes at 90°

The holder maintains together in a very easy way, up to 3 probes to measure the 3 axis (X, Y and Z) of the electric field when using 3 longitudinal eoProbe. The holder material does not perturbate the measurement.

Reference: EOP-HLD

It is not necessary to screw too tight the probes on this holder. A light torque is plenty enough.

Dimensions of the holder:

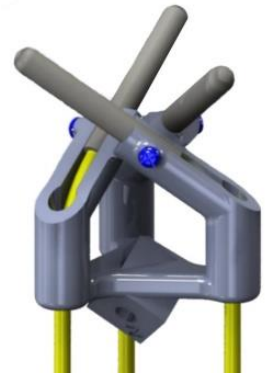
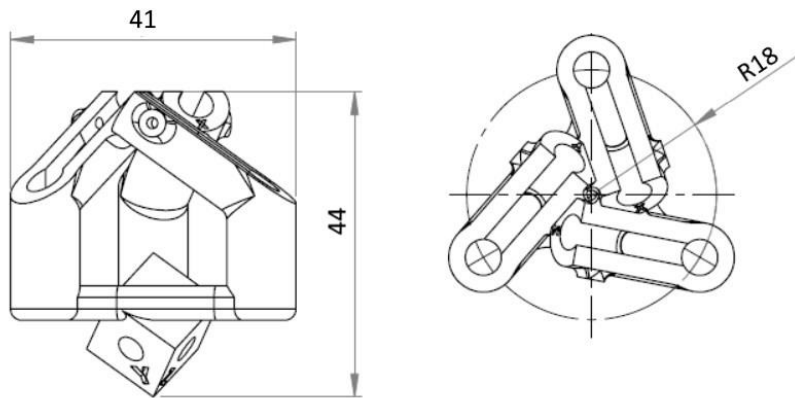

Articulated arm to maintain the probes holder

This accessory allows the mechanical maintain of the probes thanks to a flexible dielectric guide. This guide is MRI compliant meaning it does not include any magnetic part, nor metallic part. This accessory is very easy to use for rapid and accurate localisation of the probes. It is also designed to maintain the EOP-SH and EOP-HLD probes support via a specific adapter delivered when ordering both eoPod and EOP-SH or EOP-HLD. The blue dome is made from silicon for a good adherence.

Reference: eoPod



View with EOP-SH support



View with EOP-HLD support



Dimensions of eoPod

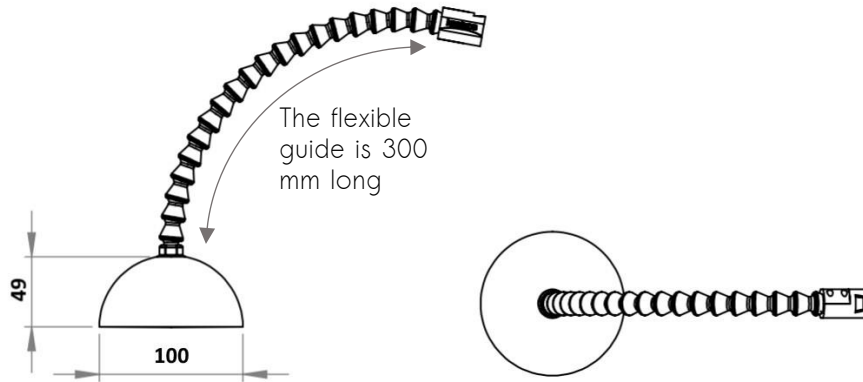

Fibre optic extension

The fibre optic extension is inserted between the eoSense instrument and an eoProbe sensor to increase the distance up to a maximum of 100 meters. The length is set with steps of 5 meters, from 5 to 95 meters. Each end of the fibre optic is connected with a ruggedized UTS-LC connector.

The sensibility of the eoProbe may be reduced between 10 to 15% at the most.

Reference: EOP-EXT



Characterisation cell for eoProbe used with liquids

The eoCal is designed for the characterisation of eoProbe linked to specific customer liquids at the relevant frequencies (maximum 200 MHz). The characterisation is performed by the customer himself. The customer has to provide the input signal to eoCal with AC voltage. The eoCal provides an output linked to the customers conditions.

Reference: eoCal

For further information, please read eoCal data sheet.



Services

Calibration

New calibration of eoProbe (with its eoSense instrument) is requested to be performed at Kapteos every 2 years.

Rental

No rental of an eoProbe or any of the above listed accessories without the rental of an eoSense instrument.

Contact us

Kapteos SAS
Bâtiment CleanSpace
354 voie Magellan
73800 Sainte-Hélène du Lac
France

contact@kapteos.com

Tel: +33 (0)4 79 62 88 34

Follow us on



(Click on icon to visit social network)

Visit our website

www.kapteos.com

